

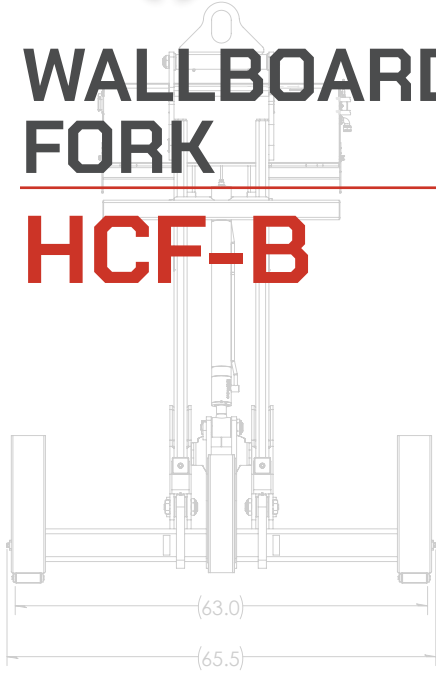

CRANE ATTACHMENTS

WALLBOARD FORK HCF-B



MULTIPLE
MODELS
AVAILABLE



STOWED POSITION

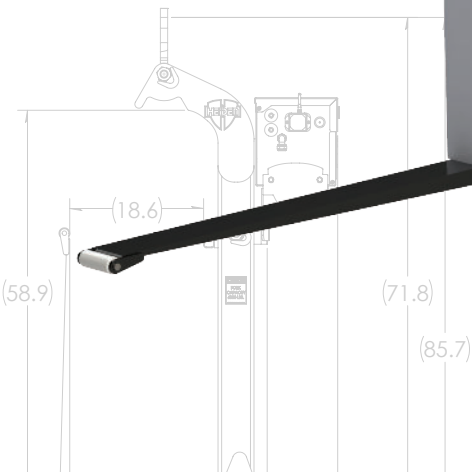

(42.5)

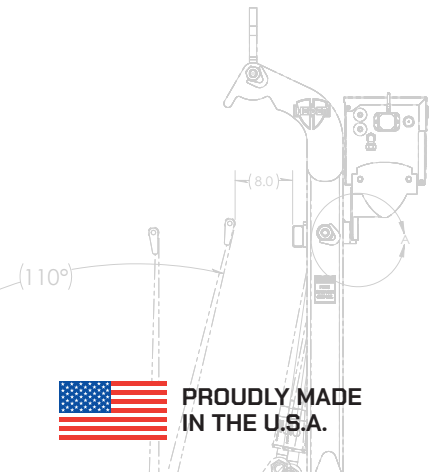

PROUDLY MADE
IN THE U.S.A.

FEATURES

HCF WALLBOARD FORK SERIES

- Wireless remote with corded backup
- 12 v pump
- On board diagnostics
- On board charger
- USB charge port

- Voltage meter
- 63" & 72" wide models
- 6,000 Lb capacity Includes attachment wt.
- Load holding hydraulic cylinder
- No minimum order quantity



HCF WALLBOARD FORK SERIES

HCF-5463 / HCF-5472

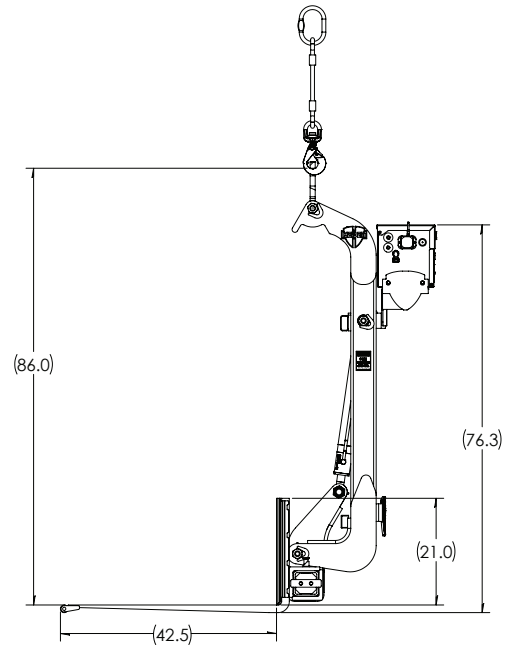
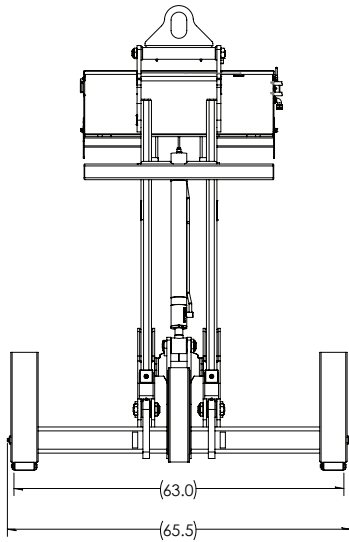

STOWED POSITION

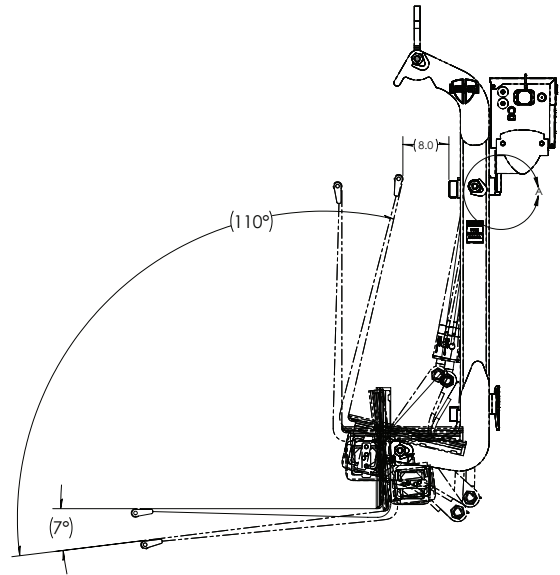
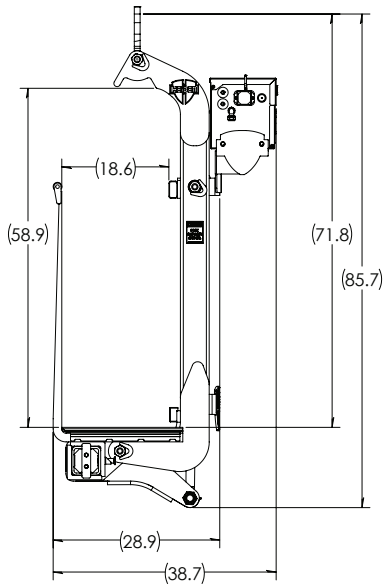

*Heiden Inc., reserves the right to change these specifications without notice and without incurring any obligation relating to such changes.

OUR RELIABILITY, DELIVERY, AND INTERCHANGEABLE CUSTOM DESIGNS WILL IMPROVE YOUR BOTTOM LINE.



Interchangeable Components



Exceptional Durability



Fast Turnaround



Made in USA

4624 Expo Dr. Manitowoc, WI 54220

Toll Free: 888.682.5779 Phone: 920.682.6111

Fax: 920.682.3174

Email: heiden@heidenco.com

HEIDENCRANE.COM



HEIDEN, INC IS AN ISO 9001-2015 CERTIFIED COMPANY



PROUDLY MADE IN THE U.S.A.