



CRANE ATTACHMENTS

HEIDEN BLT GRAPPLES

HC20 SERIES

Operating and Maintenance Manual



WARNING

For safe operation, read these rules and instructions carefully to avoid accidents that could result in Death or Serious Injury.

Heiden, Inc.

4624 Expo Drive

Manitowoc, WI 54220

(888) 682-5779

heiden@heidenco.com

www.heidencrane.com



Proudly Made in USA

Thank You

Our sincere appreciation to you on the purchase of a quality BLT Grapple that has been designed and manufactured in the USA by Heiden, Inc. Product experience of over 60 years is the cornerstone of our company and our goal is to provide you with a heavy duty BLT Grapple that will give you years of satisfaction and operation.

Our record of successful and satisfied customers is a testament of the concern for quality and designed strength that we place into each and every product we build.

This manual expresses the need for safe operation and maintenance of your BLT Grapple from Heiden, Inc. It is important that you and all of your operators of this BLT Grapple become familiar with the operation, maintenance and safety instructions found in this manual, as well as in the manual that accompanied the truck that will power your BLT Grapple. Add some common sense to the items mentioned in these manuals as a recipe for safe operation.

We invite you to look at more of our innovative products on our website:

<https://www.heidencrane.com/> or contact your local dealer to find out more.

Sincerely,
Management and Employees
Heiden, Inc.

Important Information

Record your BLT Grapple and Dealer information here for future reference

MODEL #: _____

TYPE: _____

SERIAL #: _____

DEALER NAME: _____

DEALER PHONE:(____)-____-_____

Table of Contents

1	Introduction.....	5
1.1	General.....	5
1.2	Identification Plate	6
1.3	Purpose of Heiden BLT Grapple	6
2	Warranty	7
3	Safety.....	7
3.1	General.....	7
3.2	Observe Safety Instructions.....	7
3.3	Before and During Work.....	8
3.4	Safe Maintenance.....	8
3.5	Working with Oils and Chemicals	9
4	Maintenance	9
4.1	General.....	9
4.2	Safe Maintenance.....	10
4.3	Lubrication Instructions.....	11
4.4	Recommended Grease	11
4.5	Regular Maintenance	12
4.5.1	Daily Maintenance or Maintenance Every 16 Hours	12
4.5.2	Weekly Maintenance or Maintenance Every 80 Hours	13
4.5.3	Maintenance Every 1000 Hours.....	13
4.6	Removal and Mounting of Hydraulic Cylinders	13
4.7	Removal and Mounting of BLT Grapple Jaws	13
5	Storage and Decommissioning of the Grapple	14
5.1	Storage.....	14
5.2	Dismantling and Decommissioning of the Grapple	14
6	Technical Data.....	15



Table of Contents *(cont.)*

7	BLT Grapple Parts Breakdown.....	16
7.1	HC20-BLT-2.5, HC20-BLT-3	16
7.1	HC20-BLT-2.5, HC20-BLT-3	17



1 Introduction

1.1 General

- ⇒ This manual contains instructions for operating and servicing your BLT Grapples. The information contained in this manual is essential for proper use and maintenance of your BLT Grapple.
- ⇒ If more complex repairs and maintenance are required for your BLT Grapple, it is recommended that you contact your dealer to find a qualified technician that can execute the necessary work. Heiden Inc recommends that only qualified technicians service and repair your BLT Grapple. Failure to do so could cause your BLT Grapple to not operate properly and cause serious injury or death.
- ⇒ This manual contains important information and instruction for operating your BLT Grapple safely and efficiently. This manual should be kept on hand and read by any individual that will operate your BLT Grapple. If your manual becomes lost or becomes dirty that it is impossible to read, please contact your dealer or Heiden for a replacement manual.
- ⇒ If you sell your Heiden BLT Grapple please pass this manual over to the new owner.
- ⇒ Heiden Inc continually works to improve its products and this could result in changes to your BLT Grapple that are not covered in this manual. If you need the latest information about your BLT Grapple or have questions about this manual, please contact your dealer or Heiden Inc.
- ⇒ Regular maintenance and proper operation of your BLT Grapple are the key to ensuring a long useful life of your BLT Grapple and safety of the operator. Therefore strictly observe the guidelines contained in this manual.
- ⇒ All rights reserved.

WARNING!



- **Designates possible dangerous situation.**
- **Instructions must be observed and followed.**
- **Disregarding this information may result in serious injury or death.**
- **Disregarding the operating instructions may result in accidents, downtime and may void the warranty.**

1.2 Identification Plate

- ⇒ Locate the Identification Plate on top of your BLT Grapple. This plate will have the Model number and Serial number of your BLT Grapple. This information is important when contacting your dealer/Heiden Inc with questions or if you need to order replacement parts for your BLT Grapple.



1.3 Purpose of Heiden BLT Grapples

- ⇒ Your BLT grapple is intended to be used for safely handling loose railroad ties. BLT Grapples come with continuous rotation rotators for easy manipulation of the railroad ties you pick up.

2 Warranty

- ⇒ Your BLT Grapple has a 12 month warranty that starts from the date of delivery. The warranty applies to failure from manufacturer defect or failure when operated within normal operating conditions. The warranty **does not** cover failure from the following:
 - Operator error.
 - Operating outside of normal operating conditions.
 - Failure caused by modifications not authorized by Heiden Inc.
- ⇒ Your BLT Grapple has been checked at Heiden Inc facility before its delivery to your dealer. It can be taken into immediate use after complete installation on your rig and inspection of the installation. The warranty is only effective during the warranty period if all maintenance procedures have been carried out according to the schedule set out in this manual.

3 Safety

3.1 General

- ⇒ If any of the information contained in this manual is contrary to your locally effective laws and standards, the local laws should be observed.
- ⇒ Your BLT Grapple should only be operated and serviced by individuals who have been properly trained for the purpose.

3.2 Observe Safety Instructions

- ⇒ Carefully read and make sure you understand all the safety instructions in this manual.
- ⇒ Learn how to properly operate your Heiden BLT Grapple and its controls. Never allow an untrained person to operate your Heiden BLT Grapple.
- ⇒ Keep your BLT Grapple in good working condition. Any unauthorized modifications of your BLT Grapple can impair its functionality and safe working.
- ⇒ Immediately stop using your BLT Grapple if cracks are found in the structure. Do not use until proper repairs can be made by a qualified technician.
- ⇒ **The minimum safe distance from your operating Heiden BLT Grapple is 75 yards.**

3.3 Before and During Work

- ⇒ Always check before starting to work to make sure that nobody is standing in any location where there is a risk to bodily injury or life.
- ⇒ Observe and make sure you are operating at safe distances from power lines.
- ⇒ Note the density and the slant on the ground. Always observe the job site plan.
- ⇒ **Never allow anyone to enter the 75 yard danger zone.** Stop the machine immediately if someone steps into this zone during operation.
- ⇒ Never leave the machine unsupervised when the engine is running.
- ⇒ When you handle long items note that they cause excess loads and increase the diameter of the danger zone.
- ⇒ Never stand or walk under any items being lifted.
- ⇒ Leave room for rotated, tilted and horizontally moved items.
- ⇒ Never exceed the machine's approved tilting load.

3.4 Safe Maintenance



- ⇒ **NOTE: carrying out any maintenance on your BLT Grapple with the base machine's engine running is absolutely prohibited!**
- ⇒ **Never touch any pressurized hydraulic hoses. Never tighten leaking couplings when the machine is running. Hydraulic oil flowing under high pressure is dangerous to life.**
- ⇒ Read more about Safe Maintenance procedures in Section 4.2 of the manual.

3.5 Working with Oils and Chemicals

- ⇒ **IMPORTANT: Always take notice of any environmental aspects. Close all couplings with plugs so that no oil can leak onto the ground to contaminate it.**
- ⇒ Skin exposure to oil can cause rashes. Avoid skin contact with oil. Use protective gloves. If any oil gets onto your skin, immediately wash it off. Avoid inhaling oil vapors.
- ⇒ Keep the hydraulic system clean.
- ⇒ Carefully clean the area surrounding the object being serviced before starting any maintenance procedures.



- ⇒ **NOTE: The output and pressure of the hydraulic oil must never exceed the maximum value of 3000 psi established for your BLT Grapple. Exceeding this value can cause structural defects, lead to injuries and could result in property damage.**

4 Maintenance

4.1 General

- ⇒ It is advisable to have any adjustments and repairs performed by a qualified specialist that is familiar with your Heiden BLT Grapple. Contact your local dealer to have adjustments and repairs done to your BLT Grapple.
- ⇒ Use only original spare parts when servicing your BLT Grapple. Contact your local dealer to order your parts and have them installed on your BLT Grapple.
- ⇒ Always keep the area and the device absolutely clean when servicing it.
- ⇒ Daily monitor the functioning of your BLT Grapple in order to find any loose or missing items, hydraulic leaks, hose wear, etc.
- ⇒ Make sure that there is enough hydraulic oil in the system that is powering your BLT Grapple. Too little oil can cause malfunctions, damage the pump, rotator and/or cylinders. Too little oil will also reduce the lubricating properties of the oil.

4.1 General (cont)

- ⇒ However, where the base machine is concerned, we advise that you consult the machine's own maintenance manual(s).
- ⇒ Heiden Inc. cannot assume any liability for modifications of the BLT Grapple structure or hydraulic systems, which do not conform to the original installation.
- ⇒ **IMPORTANT:** Note that when you perform e.g. the 1000 Hour Maintenance, you also need to carry out all maintenance procedures scheduled to be performed Daily or after every 80 hours of work.

4.2 Safe Maintenance



- ⇒ **NOTE: Maintenance and repair work should be carried out only by qualified technicians or maintenance workshops, using the appropriate tools and lifting devices.**
- ⇒ **NOTE: Always turn off the machine before starting any maintenance work.**
- ⇒ **NOTE: Never touch any pressurized cylinders or hoses and never stand around them.**
- ⇒ **NOTE: Never tighten leaking couplings when the machine is running. Hydraulic oil flowing, spurting out under high pressure is dangerous to life!**

- ⇒ When you perform any work around your Heiden BLT Grapple always stop the engine of the base machine and disconnect power with the main switch to avoid accidents.
- ⇒ If you leave the machine, lower the BLT Grapple firmly on the ground. It is prohibited to work under and unsupported BLT Grapple or boom.
- ⇒ Never let any inexperienced person enter the cabin of the base machine when the BLT Grapple is being inspected, serviced or repaired.
- ⇒ Never exceed the operating pressure of 3000 psi . Never adjust the hydraulic pressure without a pressure gauge.
- ⇒ Connect and disconnect the pressure gauge always when the system is not pressurized, if at all possible.

4.3 Lubrication Instructions

- ⇒ Never perform lubrication when the machine is running.
- ⇒ The BLT Grapple needs lubrication either daily or every 16 hours of work. The most suitable time to lubricate the machine is when the shift ends or operator changes.
- ⇒ The grease penetrates into the zerk easier when the machine is warm.
- ⇒ When greasing the zerks always wipe the zerk head clean before greasing.
- ⇒ Release pressure from the cylinders and make sure the BLT Grapple is resting on the ground and not hanging, this will make injecting grease into the zerks easier.
- ⇒ Inject grease until the grease coming out of the joint is clean.
- ⇒ Wipe off any excess grease that has come out.
- ⇒ Never dispose of empty grease cartridges and rags/hand towels into the environment.

4.4 Recommended Grease

- ⇒ Lubriplate LTR-2: Heavy Duty, Tacky, Red, Lithium Complex Grease

4.5 Regular Maintenance

⇒ **IMPORTANT:** Note that when you perform e.g. the 1000 Hour Maintenance, you also need to carry out all maintenance procedures scheduled to be performed Daily or after every 80 hours of work.

4.5.1 Daily Maintenance or Maintenance Every 16 Hours

1. Check for any possible oil leaks.
2. Visually check the condition of the structure and pivot pin nuts.
3. Lubricate hydraulic cylinder bearings (4 zerks)
4. Lubricate jaw bearings (4 zerks)
5. Lubricate link pins (2 Zerks)

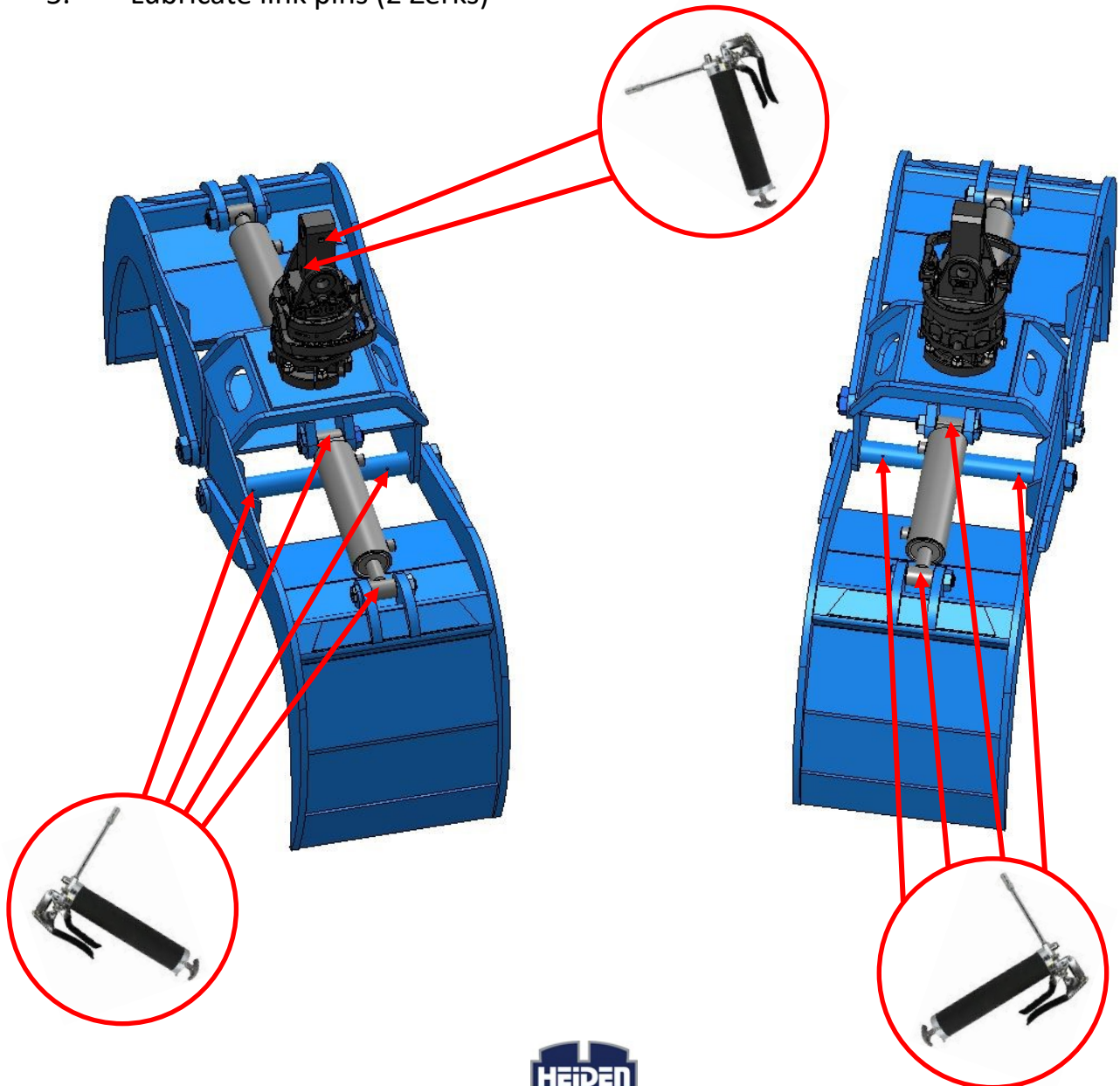

4.5.2 Weekly Maintenance or Maintenance Every 80 Hours

1. Check the pivot pin nuts.
2. Check the condition of hydraulic cylinder rods and check for any oil leaks.
3. Check the hydraulic hoses for any damage.

4.5.3 Maintenance Every 1000 Hours

1. Check the cylinder bearings, replace if necessary.
2. Check the jaw bearings, replace if necessary.
3. Check the hydraulic cylinder gaskets, replace if necessary.
4. Check for any possible cracks and repair them by welding.
5. Replace any worn or missing warning labels.

4.6 Removal and Mounting of Hydraulic Cylinders

1. Completely open jaws of BLT Grapple and place on level surface.
2. Disconnect the hydraulic hoses and close the couplings with plugs.
3. Remove the locking nuts from the pivot pins.
4. Tap the pivot pins out. Use a plastic or brass hammer and appropriate punch.
5. Assemble in the reverse order.

IMPORTANT: ALWAYS discard old locknuts and use new locknuts when reinstalling pivot pins.

4.7 Removal and Mounting of BLT Grapple Jaws

1. Completely open jaws of BLT Grapple and place on level surface.
2. Make sure head of BLT Grapple is fully supported.
3. Remove the locking nuts from the jaw pins.
4. Remove the locking nuts from pivot pin connected to jaws.
5. Tap jaw and pivot pins out. Use a plastic or brass hammer and appropriate punch.
6. Assemble in the reverse order.

IMPORTANT: ALWAYS discard old locknuts and use new locknuts when reinstalling jaw and pivot pins.

⇒ **NOTE: Any of the items listed above that need to be replaced or fixed needs to be carried out by a qualified technician.**

5 Storage and Decommissioning of the Grapple

5.1 Storage

- ⇒ **IMPORTANT: Always protect the environment. Collect any waste oil drained from the system and make sure that it is disposed of properly.**
- ⇒ Have any worn or damaged parts repaired or replaced by a qualified technician.
- ⇒ Wash the BLT Grapple and spot-paint worn places to avoid corrosion. Replace any worn or damaged warning labels.
- ⇒ Coat the entire device with a thin coat of corrosion inhibitor. In particular, coat the visible part of the hydraulic cylinder rods.
- ⇒ Inject grease in all the grease zerks (See section 4.5.1)
- ⇒ Store the BLT Grapple in a dry protected area.

5.2 Dismantling and Decommissioning of the Grapple

- ⇒ After the BLT Grapple has reached the end of its useful life, its parts can be mostly recycled.
- ⇒ The steel parts are fully recyclable. Contact your local steel recycling facility to do this.
- ⇒ Hydraulic cylinders contain oil, which needs to be drained and disposed of appropriately. Other than the gaskets, the cylinders are made of steel.
- ⇒ Hydraulic hoses should be disposed of in accordance to your local rules and regulations.

6 Technical Data

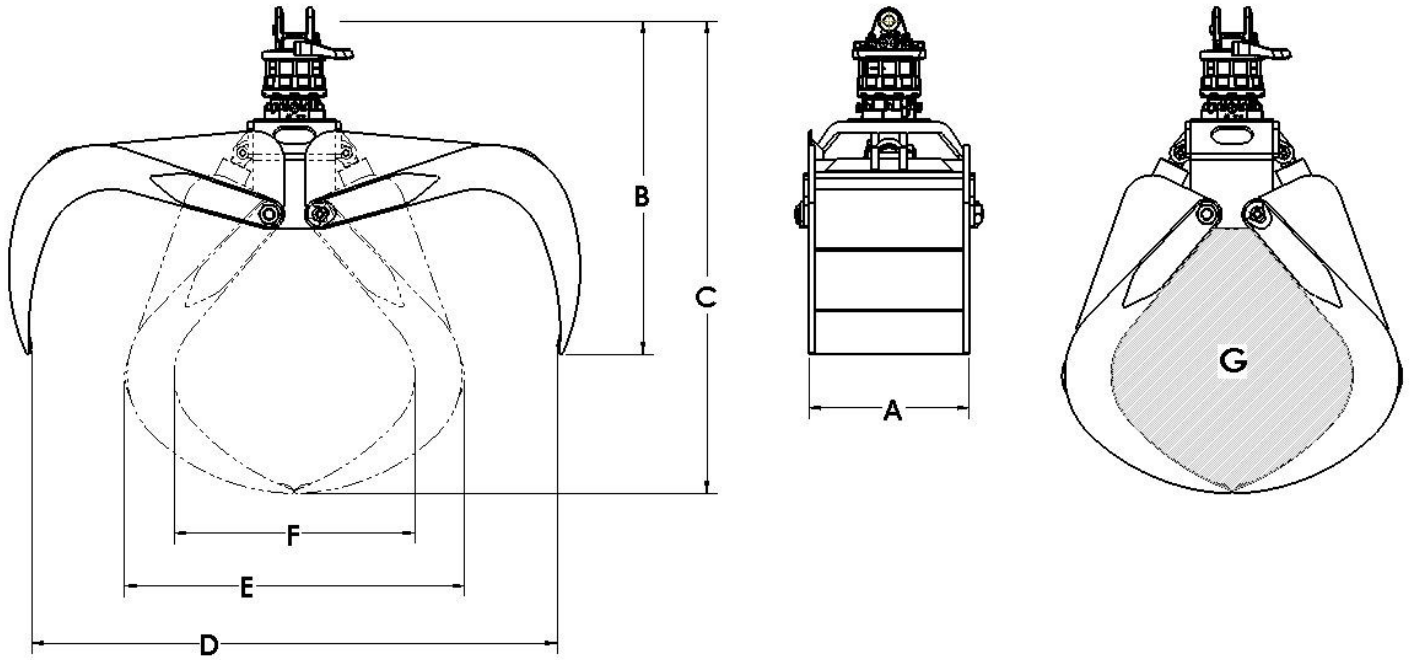

HEIDEN, INC MODEL NO.	WEIGHT W/O ROT.	WEIGHT W/ROT.	MAX OPER. PRESSURE	A	B	C	D	E	F	G (AREA)
HC20-BLT-2.5	900 lb	1020 lb	3000 psi	21.5"	46"	67"	79"	49"	34"	6.05 ft ²
HC20-BLT-3	840 lb	960 lb	3000 psi	21.5"	45"	63"	70"	46"	32"	5.10 ft ²

7 BLT Grapple Parts Breakdown

7.1 HC20-BLT-2.5 & HC20-BLT-3

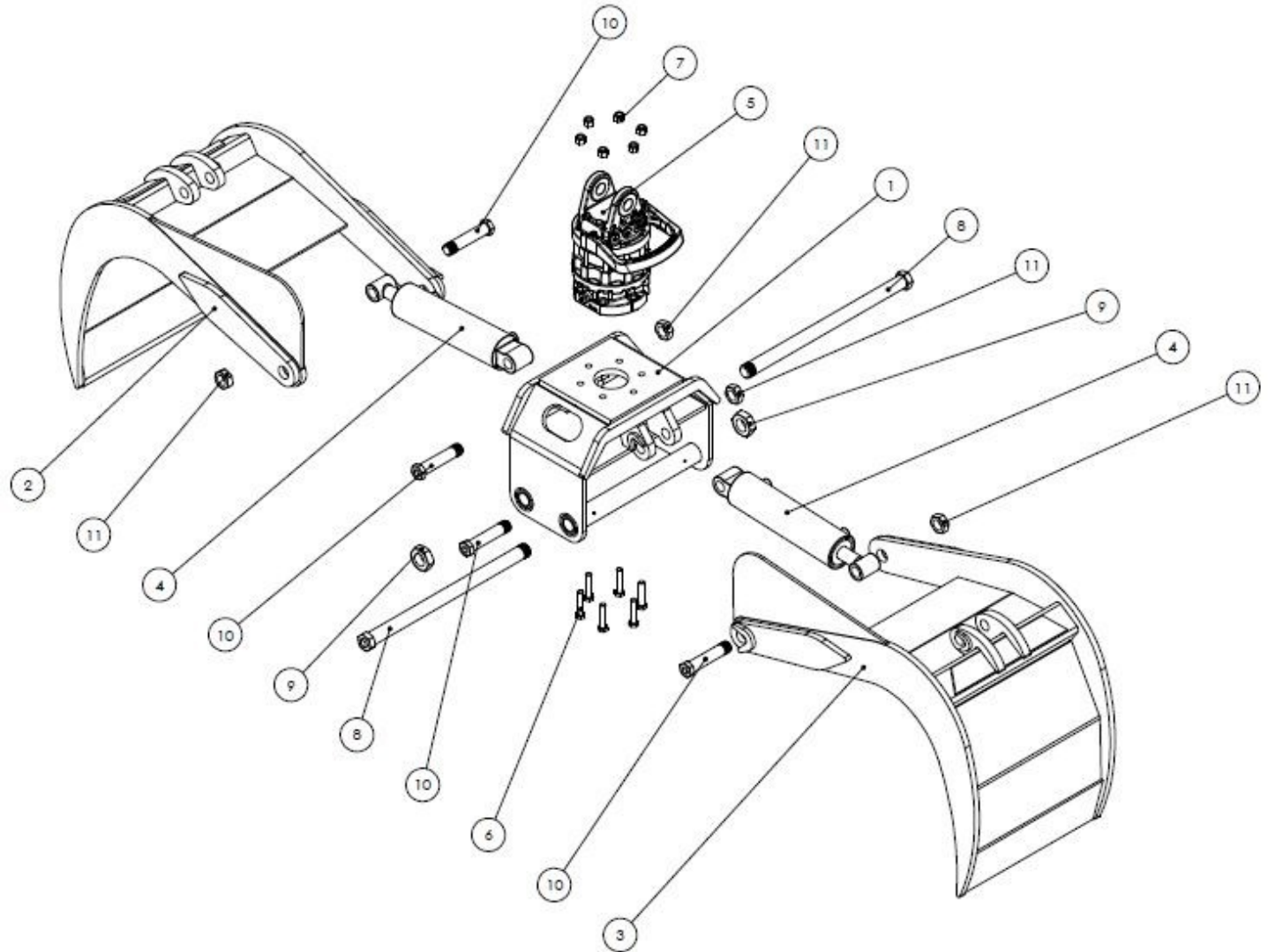

7 BLT Grapple Parts Breakdown

7.1 HC20-BLT-2.5 & HC20-BLT-3

ITEM #	QTY	DESCRIPTION	MODEL #
1	1	20 SERIES HEAD	ALL
2	1	BLT-2.5 JAW	HC20-BLT-2.5
2	1	BLT-3 JAW	HC20-BLT-3
3	1	BLT-2.5 JAW	HC20-BLT-2.5
3	1	BLT-3 JAW	HC20-BLT-3
4	2	HYDRAULIC CYLINDER	ALL
5	1	ROTATOR	ALL
6	6	5/8-18 GRADE 8 HHCS	ALL
7	6	5/8-18 NYLON LOCKNUT	ALL
8	2	JAW PIN	ALL
9	2	JAW PIN NUT	ALL
10	4	CYLINDER PIN	ALL
11	4	CYLINDER PIN NUT	ALL

